

^{*}*J/fit*

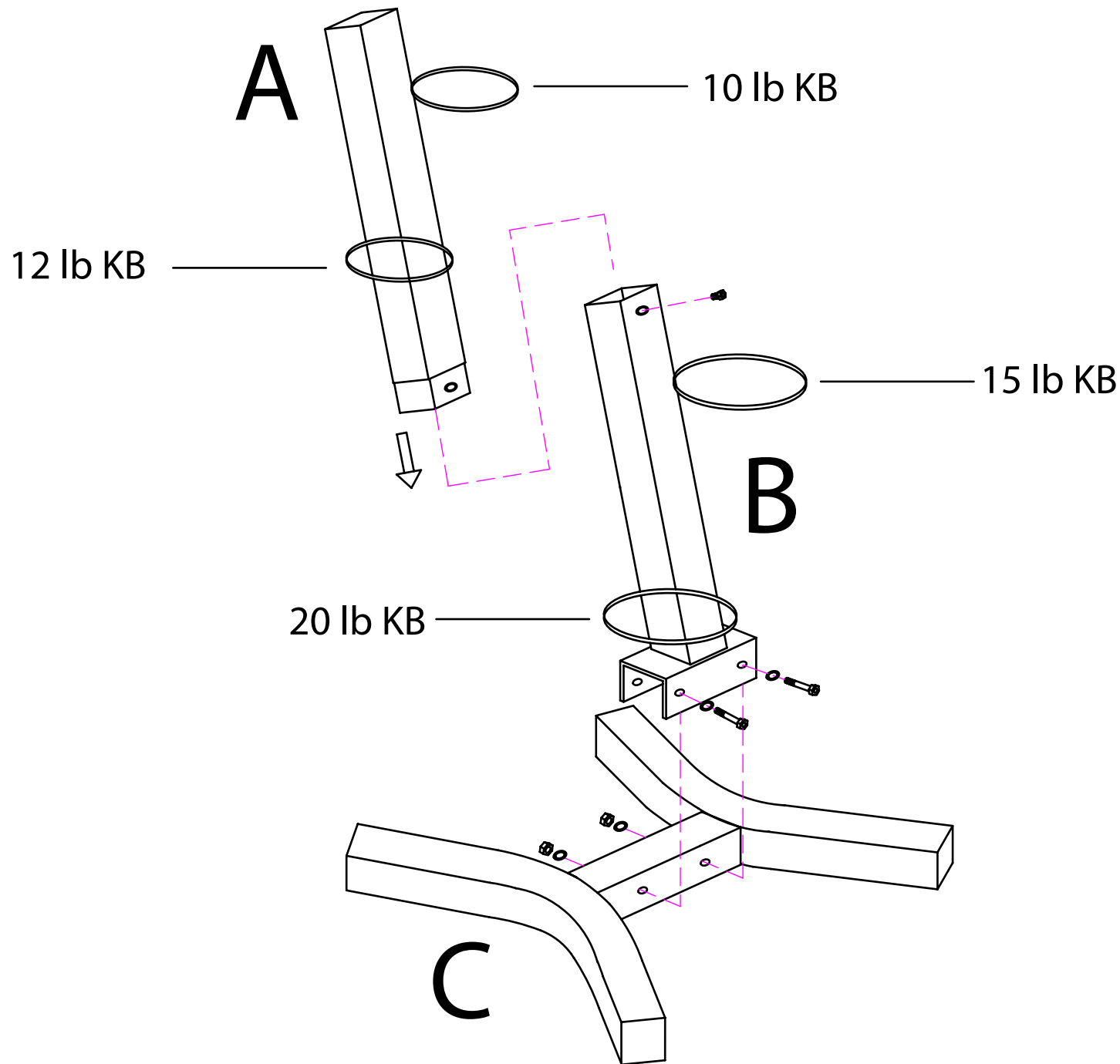

Kettlebell Rack Set



1. Insert part A into part B with rings facing forward. Slide 8mm bolt through washer, then front of unit, tighten nut.

2. Slide assembled piece onto part C. Fit the two 10mm bolts with washers, then insert through holes at base. Fit an additional washer on back end of bolts, then tighten nuts

Included Hardware:

-  10mm bolt & washers
x2
-  8mm bolt & washer
x2 (1 extra)